



SMART Board® GX (V4) Plus series

For the United States market



Display	
Screen sizes (diagonal)	65" 75" 86"
Backlight	LED
Aspect ratio	16:9
Maximum display resolution	4K UHD (3840 × 2160)
Refresh rate	60 Hz
Lifespan	≥ 50,000 hours
Brightness¹	400 cd/m ²
Display response time	≤ 8 ms
Viewing angle	178°
Glass	Full heat-tempered Anti-glare Anti-fingerprint Bonded
Frame color	White
Convenience buttons	Power Home Volume Input select Freeze frame
Sensors	Ambient light Infrared
Audio	2 integrated 20W speakers with high fidelity audio

Interactive experience	
Touch technology	Advanced infrared
Touch features	Simultaneous tool differentiation ² Object Awareness™ ³ Silktouch™
Typical touch response time	≤ 2.5 ms
Frame rate	≥ 400 Hz
Accuracy	1 mm
Minimum object size	2 mm
Multitouch capabilities	Up to 50 touch points (OS dependent)
Tools included	Pens (x2)
Tool holders	Magnetic Frame-mounted

Software	
Included	Embedded Android OS SMART Mirror SMART Notebook® SMART Product Drivers and SMART Ink®
Optional	SMART Notebook Plus Lumio™ SMART Meeting Pro® SMART TeamWorks™ SMART Remote Management

¹Brightness of individual displays can vary.

²A connected computer with SMART Product Drivers is required. Only supported in SMART Notebook and SMART Ink.

³When connected to a computer with SMART Product Drivers

Embedded Android OS	
Operating system	Android version 14.0 (forward compatible)
CPU	Octa-core
Memory	8 GB DDR4
OS architecture	64-bit
Storage	64 GB (up to 576 GB)
User interface	4K UHD (3840 × 2160)
Digital whiteboard	✓
Web browser	✓
Screen sharing	✓
Google Play™ Protect Certified	✓
Google Play Store	✓
Other features	Input select File manager Overlay Split screen Picture-in-picture (PIP) with touch pass-through Interactive widgets App library
Ability to run third-party applications	✓
Cloud storage access	✓
Languages supported	English French Spanish
Updates	Over-the-air (OTA)

OPS computing	
SMART OPS modules⁴	SMART PCM modules
OPS power	65 W
More information	See > smarttech.com/accessories

⁴The support and performance of third-party OPS (Open Pluggable Specification) and OPS-C modules may vary. Conduct proper compatibility testing to avoid potential issues.

Inputs	Front	Back
OPS PC accessory slot	–	1
microSD slot	–	1
HDMI® 2.1 4K@ 60Hz with HDCP 1.4, HDCP 2.2/2.3, and ARC support ⁵	1	2
Display Port 1.4a with HDCP 1.4 and HDCP 2.2/2.3 support	–	1
VGA video	–	1
Stereo 3.5 mm	–	1
RS-232 (DB-9 connector)	–	1
RJ45 (LAN In)	–	1
USB Type-C 4K @ 60Hz Display Port alternate mode, touch, digital audio, USB 3.2 Gen 1 (DFP) for peripherals; up to 65 W power delivery	1	–
USB Type-C 4K @ 60Hz Display Port alternate mode, touch, digital audio, USB 2.0 Hi-Speed	–	1
USB 2.0 Type-A	–	1
USB 3.2 Gen 1 Type-A	2	2
USB 2.0 Type-B	–	2
USB 3.0 Type-B	1	–

Outputs	Front	Back
HDMI 2.1 4K @ 60Hz with HDCP 1.4 and 2.3 support	–	1
USB Type-C 4K @ 60Hz Display Port alternate mode	–	1
Stereo 3.5 mm (variable)	–	1
S/PDIF optical (fixed)	–	1
RJ45 (LAN Out)	–	1

⁵ARC support is available only with the HDMI 1 input.

Included cables and accessories	Qty
Country-specific power cable	1
16' 5" (5 m) USB 2.0 A to B cable	1
6' (1.8 m) USB 3.2 Gen 1 Type-C cable, 5A	1
Pens	2
External dual-band Wi-Fi (2.4 and 5 GHz) and Bluetooth® (2.4 GHz) antennas	2
Remote control	1
AAA batteries	2
Illustrated installation instructions	1
Important information document	1

Connectivity	
Wired	RJ45 (×2) 1000BASE-T
Wi-Fi	IEEE 802.11ax (Wi-Fi 6) supporting WEP, WPA, WPA2, WPA3 PSK, and 802.1X EAP authentication protocols Wi-Fi access point
Bluetooth	5.2

Storage and operating requirements	
Power requirements	115V AC, 60 Hz
Operating temperature	32–104°F (0–40°C)
Storage temperature	14–140°F (-10–60°C)
Humidity	20–80% relative humidity, non-condensing

Power consumption	
Typical	65": 82 W 75": 107 W 86": 130 W
Standby	0.2 W

Certification and compliance	
Regulatory models	IDGX65-D IDGX75-D IDGX86-D
US / Canada	UL cUL FCC ISED TSCA CONEG Packaging Proposition 65
Performance standards	ENERGY STAR® HDMI HDCP

Purchasing information⁶

Order numbers

GX165N-V4	SMART Board® GX065-V4 Plus interactive display with embedded OS (GMS)
GX175N-V4	SMART Board GX075-V4 Plus interactive display with embedded OS (GMS)
GX186N-V4	SMART Board GX086-V4 Plus interactive display with embedded OS (GMS)

Optional accessories

See > smarttech.com/accessories

SMART Warranty

Terms and conditions and warranty upgrade options vary by region. Visit smarttech.com/warranty or contact your reseller for information.

Cable requirements

See > *SMART cables and connectors guide* (docs.smarttech.com/kb/171926)



⁶Order numbers may vary by region.

Installation, dimensions, and weights

Notes

- All dimensions $\pm 1/8"$ (0.3 cm). All weights ± 2 lb. (0.9 kg).
- Shipping dimensions and weights are for a single product that is not delivered on a pallet.
- Product ships upright.
- Leave space around the display to ensure adequate ventilation.

65" models

Dimensions

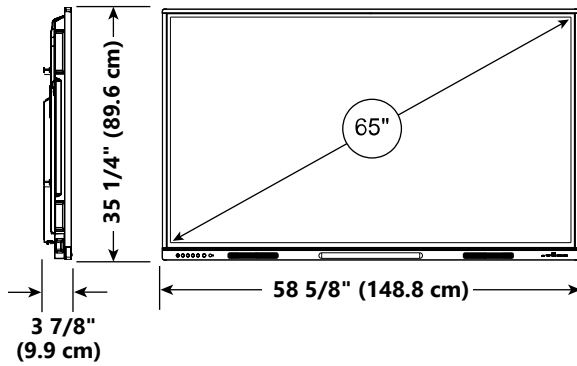

Weight

69 lb. (31 kg)

Shipping dimensions

64 1/8" \times 39 7/8" \times 7 1/4"
(162.8 cm \times 101.4 cm \times 18.5 cm)

Shipping weight

84 lb. (38 kg)

VESA mount

M8 | 600 \times 400 mm

Handles

2

75" models

Dimensions

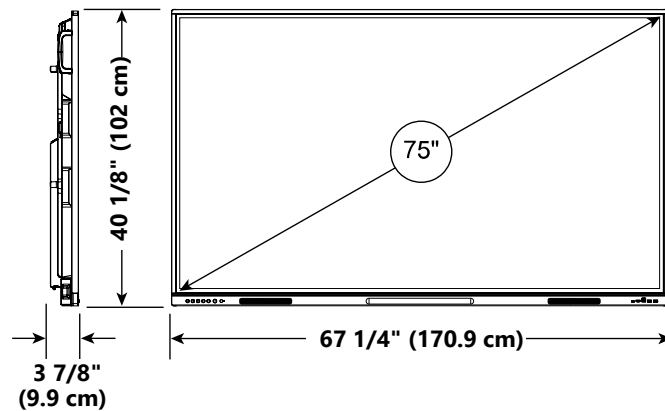

Weight

93 lb. (42 kg)

Shipping dimensions

73 3/8" \times 45 1/4" \times 7 1/4"
(186.3 cm \times 114.8 cm \times 18.5 cm)

Shipping weight

115 lb. (52 kg)

VESA mount

M8 | 800 \times 400 mm

Handles

2

Installation, dimensions, and weights (continued)

86" models

Dimensions

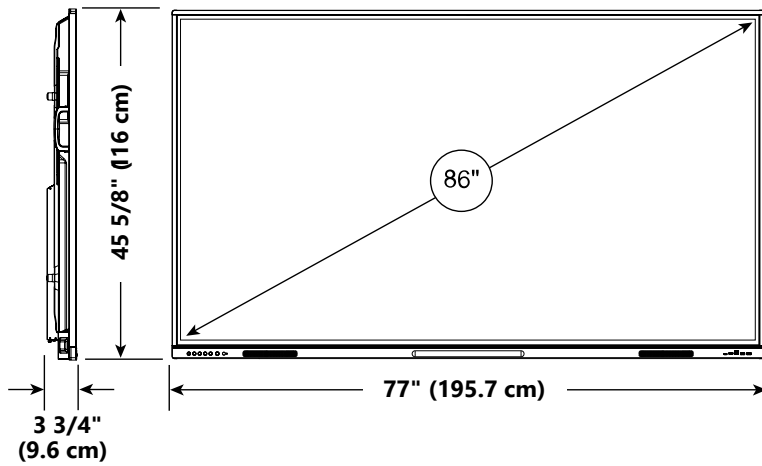

Weight

113 lb. (51 kg)

Shipping dimensions

83 1/8" x 50 7/8" x 7 1/4"
(211 cm x 129.1 cm x 18.5 cm)

Shipping weight

146 lb. (66 kg)

VESA mount

M8 | 800 x 600 mm

Handles

2

smarttech.com
smarttech.com/contact

© 2026 SMART Technologies ULC. All rights reserved. SMART Board, SMART Ink, Object Awareness, Silktouch, smarttech, the SMART logo and all SMART taglines are trademarks or registered trademarks of SMART Technologies ULC in the US and/or other countries. The Adopted Trademarks HDMI, HDMI High-Definition Multimedia Interface, and the HDMI Logo are trademarks or registered trademarks of HDMI Licensing Administrator, Inc. in the United States and other countries. Android and Chrome OS are trademarks of Google Inc. All other third-party product and company names may be trademarks of their respective owners. This product and/or use thereof is covered by one or more of the following US patents: www.smarttech.com/patents. Contents are subject to change without notice. March 9, 2026.